

A Study of Dilution Modes and TMP under Different Operational Conditions in CVVH



Jeffrey J Letteri, BS³, Zhongping Huang, PhD¹, Anil C Attaluri, PhD²,

¹Biomedical Engineering, West Chester University, West Chester, PA, USA; ²Pennsylvania State University, Middletown PA, USA and ³Renatec Consulting, Nantucket, MA, USA



Introduction

An experimental study assessing specifically the effect of dilution modes on effective solute clearance in CRRT was investigated under CVVH mode, with pure post-dilution as the reference mode. The clearances for both small and middle molecules were measured for varying degrees of post/pre-dilution balance and different flow conditions. Our results find that 1.) SM solute clearance increased as the extent of Pre decreased 2.) MM SC decreased substantially (especially in POST) with time, likely due to secondary membrane effects. 3.) The data obtained by varying Pre- and Post percentages are predictable for SM but are not entirely consistent for MM. 4.) Higher clearance values for MM can be achieved in Pre and PBP rather than in Post under low TMP. These results should be considered in the interpretation of recent CRRT dose/outcome studies.

Methods and Materials

- 6 liters heparinized bovine blood (Hct ~ 35%, 34°C-36°C) was used as blood side fluid
- An isovolemic fluid exchange was used, such that ultrafiltration rate and replacement fluid rate (QR) were the same
- Post dilution, pre-dilution and pre-pump dilution with following three operational conditions:
 - Blood flow rate: 190 mL/min, Replacement flow rate: 2 L/hr
 - Blood flow rate: 290 mL/min, Replacement flow rate: 3 L/hr
 - Blood flow rate: 380 mL/min, Replacement flow rate: 4 L/hr
- Different dilution percentages of 0% (pure POST), 25%, 50%, 75%, and 100% (pure PRE) with a blood flow rate of 290 mL/min and replacement fluid (RF) rate of 3 L/hr.
- Machine: Prismaflex, "Treatment" duration = 240 minutes.
- Hemofilter: 1.4 m² Polyarylethersulfone (HF1400, Gambro/Baxter)
- N = 3 for each filter/flow rate, dilution mode combination
- Solutes:
 - Small molecular solutes surrogates: Urea (MW: 60); Creatinine (MW: 113)
 - Middle molecules solutes surrogates: Vancomycin (MW: 1448); Inulin (MW: 5200)

Figure 1 Experimental System

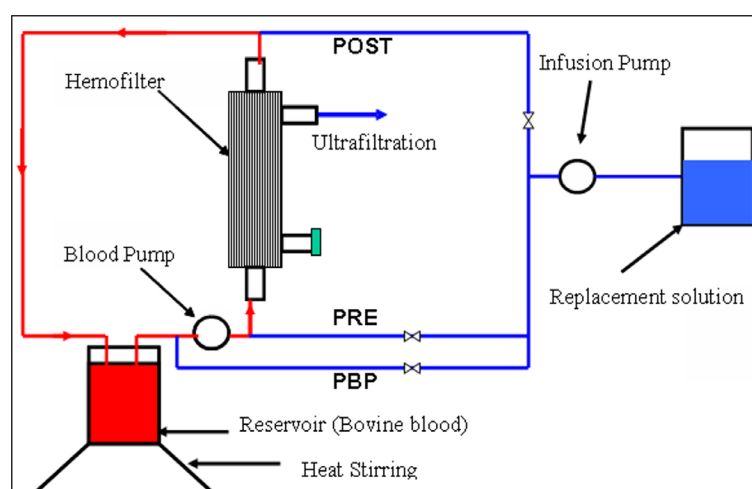

Results

Table 1 Variation of Urea and Creatine Clearances (mL/min) with Operational Conditions

	POST		PRE		PBP	
	U	C	U	C	U	C
Condition 1	34.0 ±2.0	34.0 ±1.0	27.0 ±0.8	27.8 ±1.0	25.3 ±1.9	26.0 ±0.5
Condition 2	54.0 ±1.2	55.0 ±0.7	35.1 ±0.7	35.5 ±0.3	36.4 ±0.7	35.7 ±1.4
Condition 3	71.0 ±2.0	71.0 ±1.0	52.1 ±1.7	51.6 ±0.6	49.5 ±5.6	52.8 ±3.6
P-value	6.5E-09	3.7E-09	1.1E-06	4.5E-08	4.3E-04	1.9E-05

Table 2 Variation of Inulin and Vancomycin Clearance (mL/min) with Operational Conditions

	POST		PRE		PBP	
	I	V	I	V	I	V
Condition 1	26.8 ±2.3	30.6 ±4.6	26.0 ±4.7	25.2 ±1.2	24.5 ±0.9	23.7 ±0.5
Condition 2	34.7 ±5.6	36.7 ±3.8	33.6 ±3.1	31.9 ±0.6	36.4 ±0.9	33.7 ±1.5
Condition 3	48.5 ±4.1	43.8 ±3.6	44.4 ±6.5	46.3 ±0.9	47.2 ±1.8	46.7 ±0.6
P-value	0.0014	0.02	0.014	5.36E-07	2.1E-06	2.33E-07

Figure 2 Comparison of Vancomycin and Inulin SC with Time at Different Dilution Modes under Condition #1

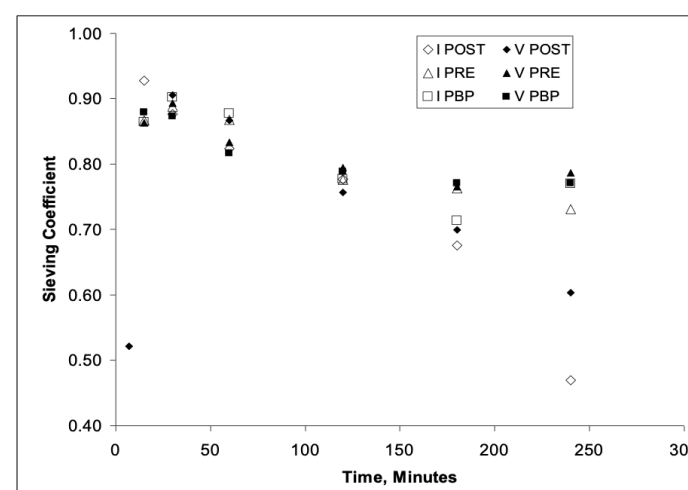

Discussion

There are significant changes ($p < 0.001$) of urea and creatinine clearance with different experimental conditions. There is significant decrease ($p < 0.01$) of urea and vancomycin clearance from post-dilution mode to pre-dilution mode and from post-dilution mode to pre-pump-dilution model. But there is no significant difference between pre-dilution and pre-pump-dilution mode. The clearance changes with time for urea and creatinine had no significant effect for all the operational conditions and dilution modes (results were not presented here).

Consistent with previous studies, the post-dilution mode provided the highest clearances under all flow conditions for the SMW solutes. However, high blood flow rates (~300 mL/min and above) were necessary to achieve high dose while also maintaining an acceptable filtration fraction. Solute clearances were not different in traditional pre-dilution and pre-blood pump administration of replacement fluid. Equivalence was possible due to automatic blood pump speed compensation of the Prismaflex system, the absence of which would have resulted in lower clearances in the pre-pump mode.

There are significant increases ($p < 0.001$) of inulin and vancomycin clearance with different experimental conditions. No significant change ($p > 0.05$) of inulin clearance between post-dilution and pre-dilution mode, post-dilution and pre-pump-dilution model, and pre-dilution and pre-pump-dilution mode were observed.

There are significant reduction of inulin and vancomycin SC with time. But the change in SC with time in post-dilution mode are the most significant ($p < 10^{-9}$) among other two dilution modes. This indicates that PRE and PBP dilution modes may develop high shear forces which reduces boundary layer on membrane surface. Decreases in MM SC and Clearance, in concert with increases in TMP w/o changes in filter pressure over time are so significant to postulate that they would reduce to nothing in as soon as 24 hours.

Conclusions

- Small MW solute clearance increased as the extent of predilution decreased.
- Middle MW SC decreased substantially (especially in POST) with time, most likely due to secondary membrane effects.
- Higher clearance values for MMW solutes can be achieved in PRE and PBP rather than in POST, but under low TMP. It is clear that MM Clearance is all but gone in less than 12 hours of CRRT

THE 28TH INTERNATIONAL CONFERENCE ON
ADVANCES IN CRITICAL CARE NEPHROLOGY

AKI & CRRT 2023

MARCH 29-APRIL 1, 2023

MARRIOTT MARQUIS SAN DIEGO

SAN DIEGO, CALIFORNIA